

UNO R3 [Atmega 328P-AU+CH340G]

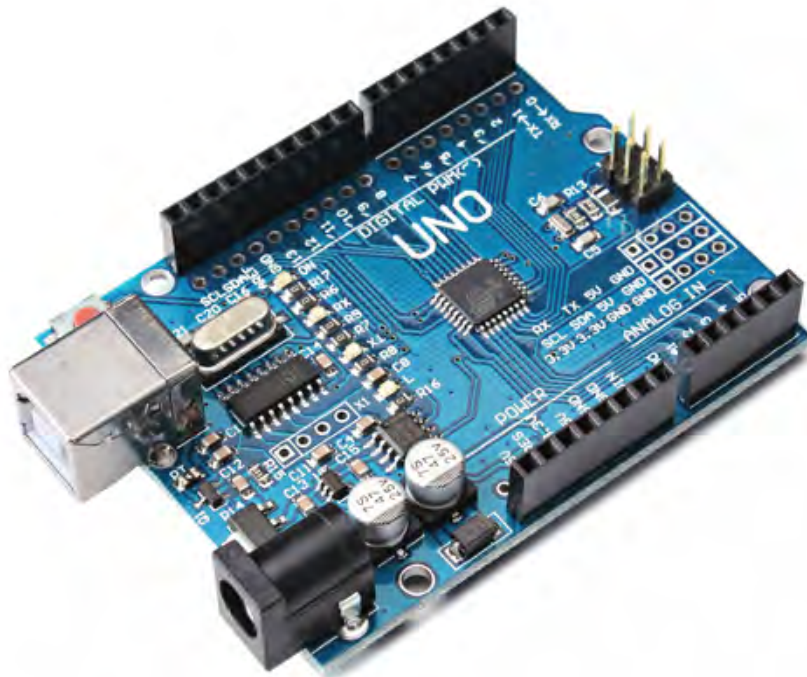

Product Overview

The Arduino Uno Clone is an easy to use, open source controller. Simply connect to a pc and begin using.

The Arduino Uno Clone is a microcontroller board based on the ATmega328. It has 14 digital input/output pins (of which 6 can be used as PWM outputs), 6 analog inputs, a 16 MHz ceramic resonator, a USB connection, a power jack, an ICSP header, and a reset button. It contains everything needed to support the microcontroller; simply connect it to a computer with a USB cable or power it with a AC-to-DC adapter or battery to get started.

Main Changes from the older version:

- Add two rows of the holes for the pins. So it can be connected with normal Dupont line.
- Add 3 rows of holes for wiring.
- Change the in-line package of ATMEGA328P to flat package.

Index

CH340G Driver Download link:

Driver download:

USB CH341/CH340 WINDOWS98/ME/2000/XP/Server 2003/VISTA/, Server 2008/Win7/Win8 32/64 <http://www.5v.ru/zip/ch341ser.zip>

USB CH341/CH340 LINUX http://www.5v.ru/zip/ch341ser_linux.zip

USB CH341/CH340 MAC OS32,MAC OS64 http://www.5v.ru/zip/ch341ser_mac.zip

CH340 driver download here: <http://www.wch.cn/downloads.php?name=pro&proid=65>



Technical Specification



EAGLE files: [arduino-duemilanove-uno-design.zip](#) Schematic: [arduino-uno-schematic.pdf](#)

Summary

Microcontroller	ATmega328P-AU
Operating Voltage	5V
Input Voltage (recommended)	7-12V
Input Voltage (limits)	6-20V
Digital I/O Pins	14 (of which 6 provide PWM output)
Analog Input Pins	6
DC Current per I/O Pin	40 mA
DC Current for 3.3V Pin	50 mA
Flash Memory	32 KB of which 0.5 KB used by bootloader
SRAM	2 KB
EEPROM	1 KB
Clock Speed	16 MHz

the board





Power

The Uno can be powered via the USB connection or with an external power supply. The power source is selected automatically.

External (non-USB) power can come either from an AC-to-DC adapter (wall-wart) or battery. The adapter can be connected by plugging a 2.1mm center-positive plug into the board's power jack. Leads from a battery can be inserted in the Gnd and Vin pin headers of the POWER connector.

The board can operate on an external supply of 6 to 20 volts. If supplied with less than 7V, however, the 5V pin may supply less than five volts and the board may be unstable. If using more than 12V, the voltage regulator may overheat and damage the board. The recommended range is 7 to 12 volts.

The power pins are as follows:

- **VIN.** The input voltage to the Arduino board when it's using an external power source (as opposed to 5 volts from the USB connection or other regulated power source). You can supply voltage through this pin, or, if supplying voltage via the power jack, access it through this pin.
- **5V.** The regulated power supply used to power the microcontroller and other components on the board. This can come either from VIN via an on-board regulator, or be supplied by USB or another regulated 5V supply.
- **3V3.** A 3.3 volt supply generated by the on-board regulator. Maximum current draw is 50 mA.
- **GND.** Ground pins.

Memory

The Atmega328 has 32 KB of flash memory for storing code (of which 0,5 KB is used for the bootloader); It has also 2 KB of SRAM and 1 KB of EEPROM (which can be read and written with the [EEPROM library](#)).

Input and Output

Each of the 14 digital pins on the Uno can be used as an input or output, using [pinMode\(\)](#), [digitalWrite\(\)](#), and [digitalRead\(\)](#) functions. They operate at 5 volts. Each pin can provide or receive a maximum of 40 mA and has an internal pull-up resistor (disconnected by default) of 20-50 kOhms. In addition, some pins have specialized functions:

- **Serial: 0 (RX) and 1 (TX).** Used to receive (RX) and transmit (TX) TTL serial data. These pins are connected to the corresponding pins of the ATmega8U2 USB-to-TTL Serial chip .
- **External Interrupts: 2 and 3.** These pins can be configured to trigger an interrupt on a low value, a rising or falling edge, or a change in value. See the [attachInterrupt\(\)](#) function for details.
- **PWM: 3, 5, 6, 9, 10, and 11.** Provide 8-bit PWM output with the [analogWrite\(\)](#) function.
- **SPI: 10 (SS), 11 (MOSI), 12 (MISO), 13 (SCK).** These pins support SPI communication, which, although provided by the underlying hardware, is not currently included in the Arduino language.
- **LED: 13.** There is a built-in LED connected to digital pin 13. When the pin is HIGH value, the LED is on, when the pin is LOW, it's off.



The Uno has 6 analog inputs, each of which provide 10 bits of resolution (i.e. 1024 different values). By default they measure from ground to 5 volts, though is it possible to change the upper end of their range using the AREF pin and the [analogReference\(\)](#) function. Additionally, some pins have specialized functionality:

- **I²C: 4 (SDA) and 5 (SCL)**. Support I²C (TWI) communication using the [Wire library](#).

There are a couple of other pins on the board:

- **AREF**. Reference voltage for the analog inputs. Used with [analogReference\(\)](#).
- **Reset**. Bring this line LOW to reset the microcontroller. Typically used to add a reset button to shields which block the one on the board.

See also the [mapping between Arduino pins and Atmega328 ports](#).

The Arduino software includes a serial monitor which allows simple textual data to be sent to and from the Arduino board. The RX and TX LEDs on the board will flash when data is being transmitted via the USB-to-serial chip and USB connection to the computer (but not for serial communication on pins 0 and 1).

A [SoftwareSerial library](#) allows for serial communication on any of the Uno's digital pins.

The ATmega328 also support I2C (TWI) and SPI communication. The Arduino software includes a Wire library to simplify use of the I2C bus; see the [documentation](#) for details. To use the SPI communication, please see the ATmega328 datasheet.

Programming

The Arduino Uno can be programmed with the Arduino software ([download](#)). Select "Arduino Uno w/ ATmega328" from the **Tools > Board** menu (according to the microcontroller on your board). For details, see the [reference](#) and [tutorials](#).

The ATmega328 on the Arduino Uno comes preburned with a [bootloader](#) that allows you to upload new code to it without the use of an external hardware programmer. It communicates using the original STK500 protocol ([reference](#), [C header files](#)).

You can also bypass the bootloader and program the microcontroller through the ICSP (In-Circuit Serial Programming) header; see [these instructions](#) for details.



Automatic (Software) Reset

Rather than requiring a physical press of the reset button before an upload, the Arduino Uno is designed in a way that allows it to be reset by software running on a connected computer. One of the hardware flow control lines (DTR) of the ATmega8U2 is connected to the reset line of the ATmega328 via a 100 nanofarad capacitor. When this line is asserted (taken low), the reset line drops long enough to reset the chip. The Arduino software uses this capability to allow you to upload code by simply pressing the upload button in the Arduino environment. This means that the bootloader can have a shorter timeout, as the lowering of DTR can be well-coordinated with the start of the upload.

This setup has other implications. When the Uno is connected to either a computer running Mac OS X or Linux, it resets each time a connection is made to it from software (via USB). For the following half-second or so, the bootloader is running on the Uno. While it is programmed to ignore malformed data (i.e. anything besides an upload of new code), it will intercept the first few bytes of data sent to the board after a connection is opened. If a sketch running on the board receives one-time configuration or other data when it first starts, make sure that the software with which it communicates waits a second after opening the connection and before sending this data.

The Uno contains a trace that can be cut to disable the auto-reset. The pads on either side of the trace can be soldered together to re-enable it. It's labeled "RESET-EN". You may also be able to disable the auto-reset by connecting a 110 ohm resistor from 5V to the reset line; see [this forum thread](#) for details.

USB Overcurrent Protection

The Arduino Uno has a resettable polyfuse that protects your computer's USB ports from shorts and overcurrent. Although most computers provide their own internal protection, the fuse provides an extra layer of protection. If more than 500 mA is applied to the USB port, the fuse will automatically break the connection until the short or overload is removed.

Physical Characteristics

The maximum length and width of the Uno PCB are 2.7 and 2.1 inches respectively, with the USB connector and power jack extending beyond the former dimension. Three screw holes allow the board to be attached to a surface or case. Note that the distance between digital pins 7 and 8 is 160 mil (0.16"), not an even multiple of the 100 mil spacing of the other pins.



How to use Arduino



Arduino can sense the environment by receiving input from a variety of sensors and can affect its surroundings by controlling lights, motors, and other actuators. The microcontroller on the board is programmed using the [Arduino programming language](#) (based on [Wiring](#)) and the Arduino development environment (based on [Processing](#)). Arduino projects can be stand-alone or they can communicate with software on running on a computer (e.g. Flash, Processing, MaxMSP).

Arduino is a cross-platoform program. You'll have to follow different instructions for your personal OS. Check on the [Arduino site](#) for the latest instructions. <http://arduino.cc/en/Guide/HomePage>

Linux Install

Windows Install

Once you have downloaded/unzipped the arduino IDE, you can Plug the Arduino to your PC via USB cable.

Blink led

Now you're actually ready to "burn" your first program on the arduino board. To select "blink led", the physical translation of the well known programming "hello world", select

**File>Sketchbook>
Arduino-0017>Examples>
Digital>Blink**

Once you have your skecth you'll see something very close to the screenshot on the right.

In **Tools>Board** select

Now you have to go to **Tools>SerialPort** and select the right serial port, the one arduino is attached to.

```

Blink | Arduino 0017
File Edit Sketch Tools Help
Blink $
int ledPin = 13; // LED connected to digital pin 13

// The setup() method runs once, when the sketch starts

void setup() {
  // initialize the digital pin as an output:
  pinMode(ledPin, OUTPUT);
}

// the loop() method runs over and over again,
// as long as the Arduino has power

void loop()
{
  digitalWrite(ledPin, HIGH); // set the LED on
  delay(1000); // wait for a second
  digitalWrite(ledPin, LOW); // set the LED off
  delay(1000); // wait for a second
}
  
```

Press Compile button (to check for errors)

Upload

TX RX Flashing

Blinking Led!

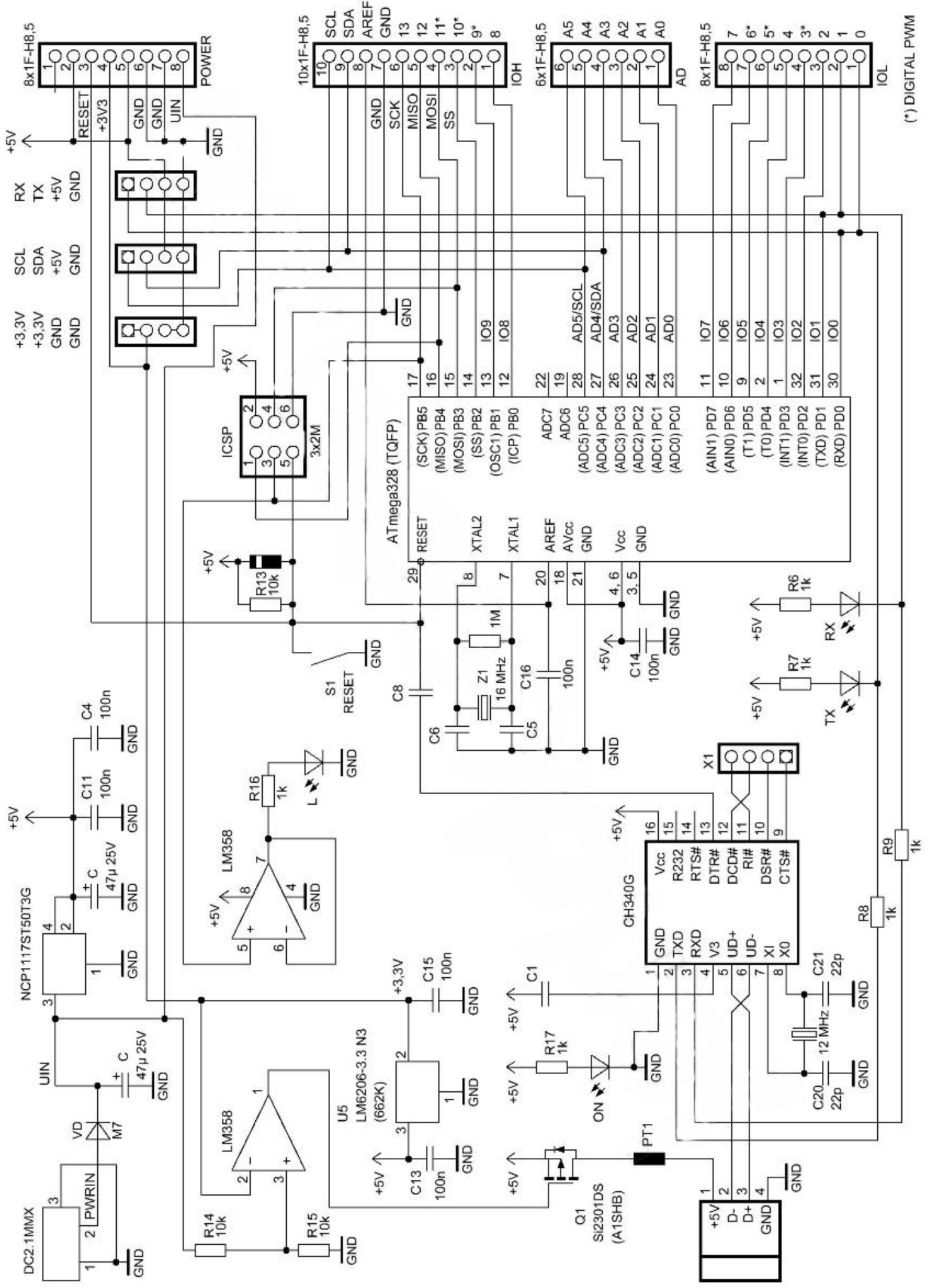

(*) DIGITAL PWM

